

DIGITECH TEXAS LT/X2 UV FLATBED PRINTER

High Productivity, Precision, Quality

Designed from the ground up by DigiTech, a U.S. company well versed in large format UV printer technology, the DigiTech Texas LT/X2 printer represents a significant leap in productivity, precision, and overall quality.

The Texas LT/X2 series printers come in two configurations: CMYK or CMYK plus White. These printers offer a spacious image area measuring five feet by ten feet and can accommodate substrates with a maximum thickness of four inches. What sets the Texas printer apart is its meticulous attention to detail in both design and manufacturing, resulting in exceptional printing capabilities, remarkable output, and outstanding quality. Reliability is a crucial aspect in a production environment where uninterrupted operation is essential, and the Texas printer excels in this aspect. Moreover, the standard auto-unloader feature helps to enhance workflow design, reducing the need for manual labor. This allows for continuous printing and finishing, efficiently handled by a single operator.

BUILT SMART FOR PRODUCTION ENVIRONMENTS

Precision Built

The TruFire Precision Print System (PPS) by DigiTech encompasses a range of design refinements that offer exceptional dot placement accuracy, reliability, and productivity.

Dot placement accuracy is important for producing the highest quality printing. By ensuring the vacuum table is flat across the entire surface, the predictability and repeatability of where the ink drops land are vastly improved. DigiTech has gone to great lengths to design a vacuum table that is not only accurate but strong enough to withstand heavy use without harm, such as operators walking on the surface, and still delivers an expected twenty-year life.



- Durable and flat machined vacuum table designed to provide an exceptional degree of flatness.
- X-axis accurate across the bridge to 1 micron; Y-axis is accurate to 1 micron on both sides of the gantry.
- TruFire PPS is an interactive user interface to give the operator complete control.
- Software aided printhead alignment process for easy, accurate alignment.

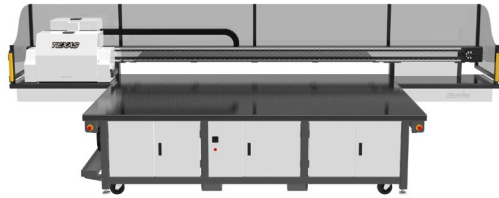

Productivity

The Texas media handling includes features that aid a single operator to be optimally productive. This starts with a registration pin system to help the operator accurately and repeatedly load boards in the required spot. The two-zone vacuum table, featuring two separate high-performance vacuum pumps, holds the board down firmly in place while printing. Once the printing is completed, the operator can enjoy the benefit of a reversable air flow to lift the board off the table for easy removal by hand or by utilizing the auto-unloader.

The auto-unloader brings the Texas into a special class of printers, one with a degree of automation that helps to reduce board changeover times. The DigiTech system has a device built onto the backside of the bridge (gantry) that consists of a rigid aluminum frame supporting a row of suction cups. Once the print finishes and the bridge returns to the home position, the suction cups drop, contact the far edge of the substrate, and lift. The bridge then begins moving away again and pulls the board with it, off the table, and then drops the board onto a pallet or the optional conveyor and cutting digital finishing system from Colex with a camera that scans a barcode printed on the board unique for that job. The Colex cutter can then automatically begin cutting. Meanwhile, the Texas printer can be already printing the next copy or job without interruption.

Maximizing Uptime

The Texas UV flatbed printer by DigiTech prioritizes maintenance to minimize downtime. Its impressive linear drive system allows for speedy and accurate movement of the bridge and carriage. This technology eliminates the need for belts, lead screws, or rack-and-pinion systems that are prone to wear. The linear encoder strips, embedded in precision steel rails, protect the system from damage throughout the printer's lifespan. The ink recirculation system addresses the common issue of blocked printhead nozzles, especially with white ink. White ink is recirculated from the bottom of the tank through the printhead, while the ink tanks are affixed to the moving bridge for natural agitation during printing

The Texas LT/X2 is designed with serviceability in mind, based on DigiTech's experience as a large format printer service organization. In case of an issue, a technician can remotely connect to the DigiTech Texas printer controller using TeamViewer. This enables DigiTech to either diagnose and potentially resolve the problem or guide the operator in replacing a part from the included Spares Kit. By focusing on reliability and ease of service, the Texas UV flatbed printer helps eliminate downtime, resulting in efficient and uninterrupted printing operations.

Example Production Speeds

	Time Per 4' x 8' Board	Printing ft ² /Hr Width 8 ft. / 10 ft
Coro Sign Mode 2 Pass¹	28 Sec	4,100 / 4,500
3 Pass	45 Sec	2,875 / 3,250
3 Pass Curemask	59 Sec	2,250 / 2,550
5 Pass Curemask	89 Sec	1,440 / 1,550

¹ Special jetting mode in Binary 14 picoliter jetting mode

Optional Conveyor and Cutting Solution from Colex



Help maximize your productivity with the optional conveyor and cutting system from Colex, seamlessly integrated with the Texas LT/X2 printer.

This automated system comprises of bi-directional conveyors, conveyor extension modules, and the Colex Sharpcut SXC1732 flatbed cutting tables, offering you a comprehensive print-to-cut workflow solution. With its modular design, the conveyor/cutting system can be configured in various production setups, allowing for optimal productivity.

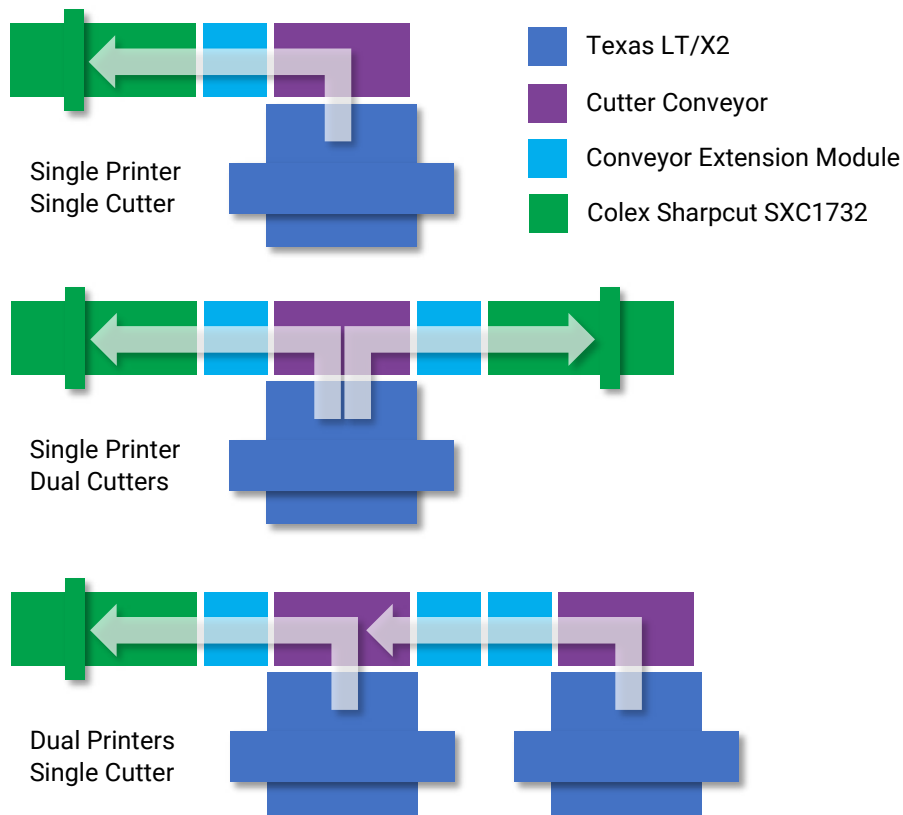

Modular Design for Various Print and Cutting Workflows

CUTTING SOLUTION COMPONENTS	
Colex Sharpcut SXC1732	5' x 10' Conveyor Table Cutter Electrical Requirements: Single Phase 220V, 50 A
Print to Cutter Conveyor	5' x 10' Bidirectional Conveyor Electrical Requirements: 110V, 5 A
Conveyor Extension Module	5' x 5' Electrical Requirements: 110V, 5 A

Texas LT/X2 Printer Specifications

SPECIFICATIONS	
Printer Design	UV True Flatbed Printer
UV Curing Technology	LED-UV
Table Size	5' x 10'
Vacuum Sections	Zoned 4' x 8' and 5' x 10'
Rigid Media Thickness	Up to 6"
Printing Accuracy	X-Axis (across Bridge): 1 micron Y-Axis: 1 micron both sides of gantry
Printhead Technology	Kyocera Dual Row Staggered
Grayscale Technology	4, 6, 10, and 14 picoliters
Print Speeds	Up to 4,500 sq. ft. per hour (Coro Sign Mode 2 Pass)
Auto Unloader	Changes sheets of media in less than 10 seconds
Ink Channel Configuration	Utilizes greyscale printing capability with 3 different shades for CMYK, Eliminates the need for light colors
Four Color	CMYKKYMC
Four Color plus White	CMYKWWKYMC
RIP Requirements	Onyx Version 19 or Greater, Caldera, ErgoSoft
Network Requirements	10 baseT with Dedicated IP Address
Electrical Requirements	Single Phase (2 lines plus ground), 208-240VAC, 50/60 Hz, 60A
Air Requirements	
Pressure	100-150 psi
Volume Capacity	5 scfm peak
Environmental	
Temperature	70-75 °F
Relative Humidity	40% - 55% RH
Atmosphere	Well Ventilated, Low Dust
Printer Dimensions (L x W x H)	222.3" x 113.1" x 69.2"
Weight	6,500 lbs.



Large Format Solutions
100 Park Blvd., Itasca, IL 60143

CSA.CANON.COM
1-800-714-4427 | us.info@csa.canon.com

Canon is a registered trademark of Canon Inc. in the United States and elsewhere. All other referenced product names and marks are trademarks of their respective owners and are hereby acknowledged. Neither Canon Inc. nor Canon U.S.A., Inc. nor Canon Solutions America, Inc. represents or warrants any third-party product or feature referenced hereunder. Not responsible for typographical errors. Availability, prices, and specifications are subject to change without notice. Not responsible for typographical errors. Neither Canon Inc., nor Canon U.S.A., Inc., nor Canon Solutions America, Inc. represents or warrants any third-party product or feature referenced hereunder. Print speeds are based on internal testing, and may vary depending on volumes and size, type, and media orientation settings. Though stated output maximums represent the machine's maximum output in a given period, it is not recommended to operate the machine at or beyond such maximums on an ongoing basis. Printer output images may be simulated. Products may be shown with optional accessories.
© 2023 Canon Solutions America, Inc. All rights reserved.
10/23-1063-7498